









-  x6
-  x56
-  x1
-  x20
-  x68
-  x129
-  x4
-  x4

Construction des jambes

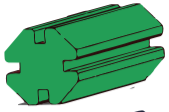
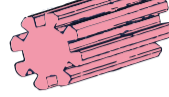
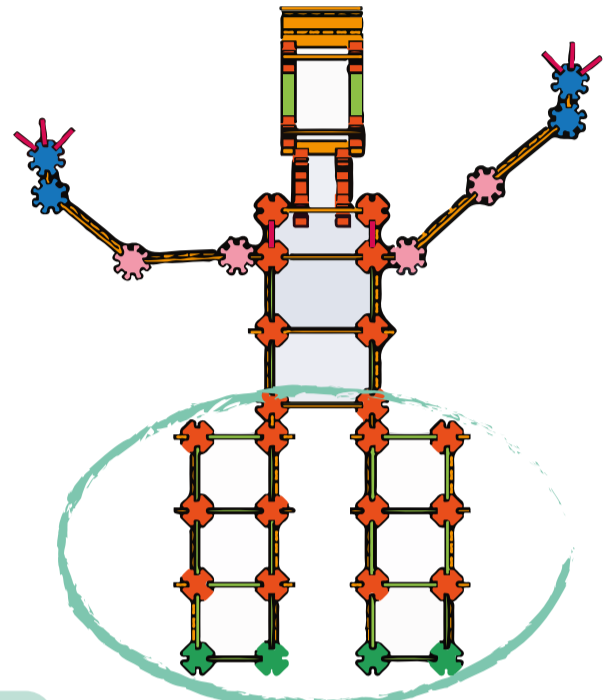

1  x2  x8

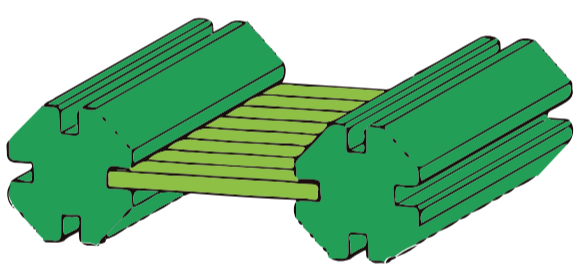

2  x4  x4

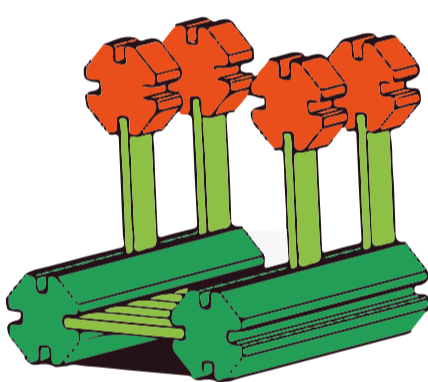

3  x2  x2

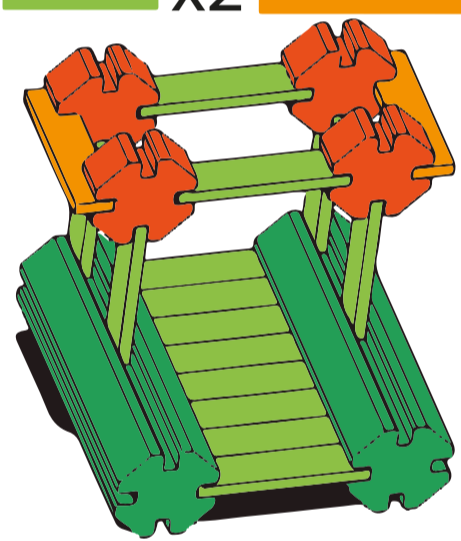

4  x4

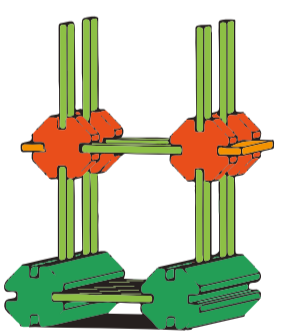

5  x4  x2  x2

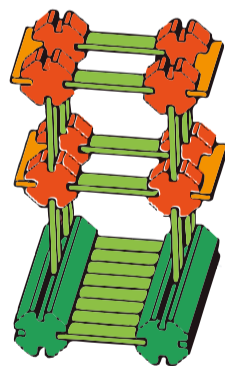

6  x4  x6  x2

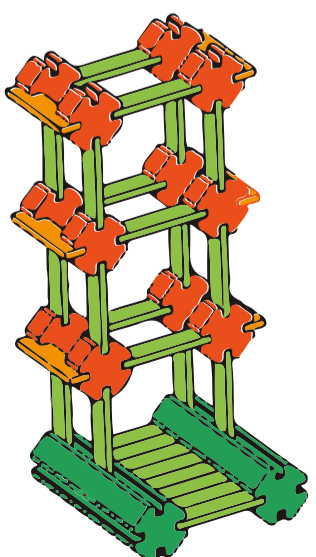

7 REPETER les étapes 1 à 6 pour faire la 2ème jambe.

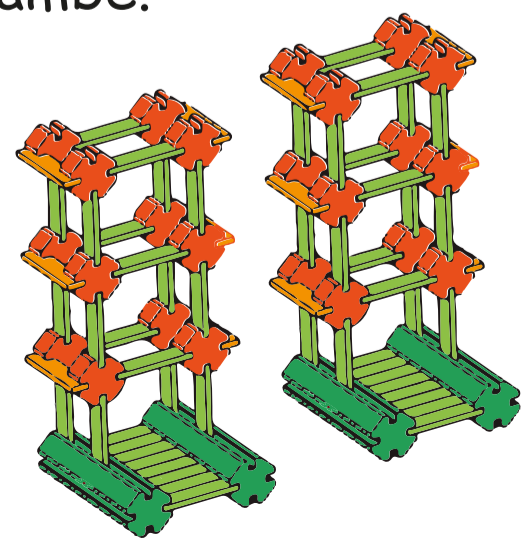

Construction du corps

8  x4  x2

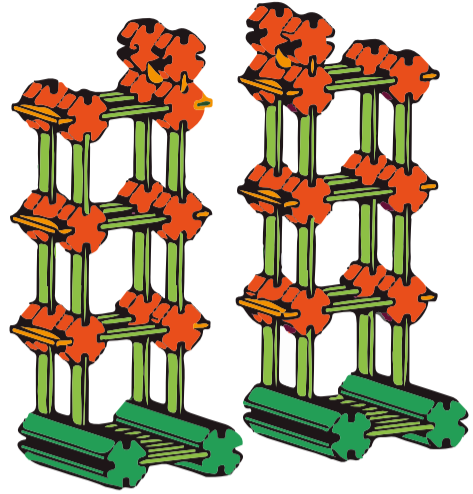

9  x2

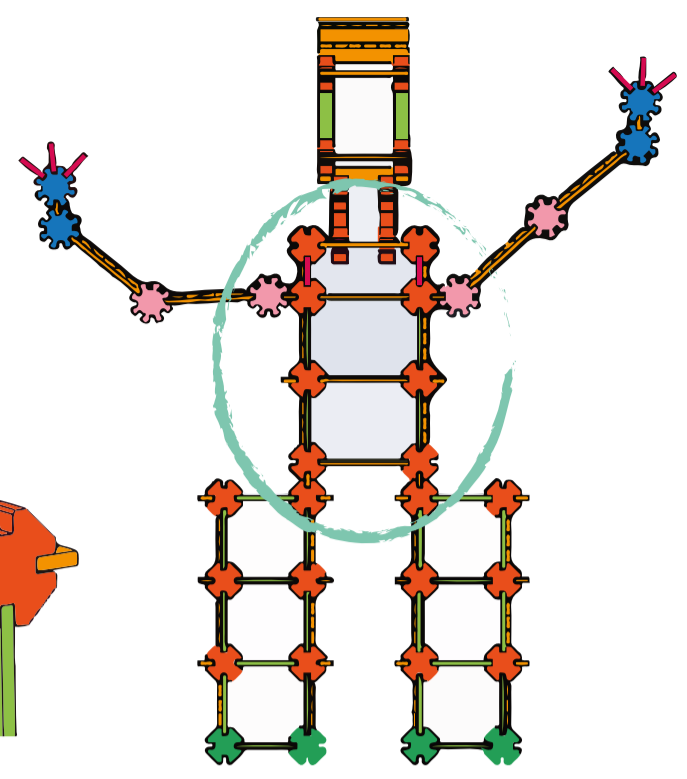
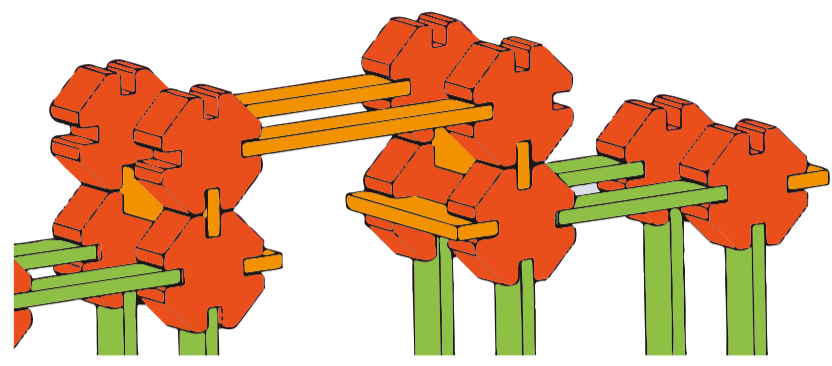

10  x4

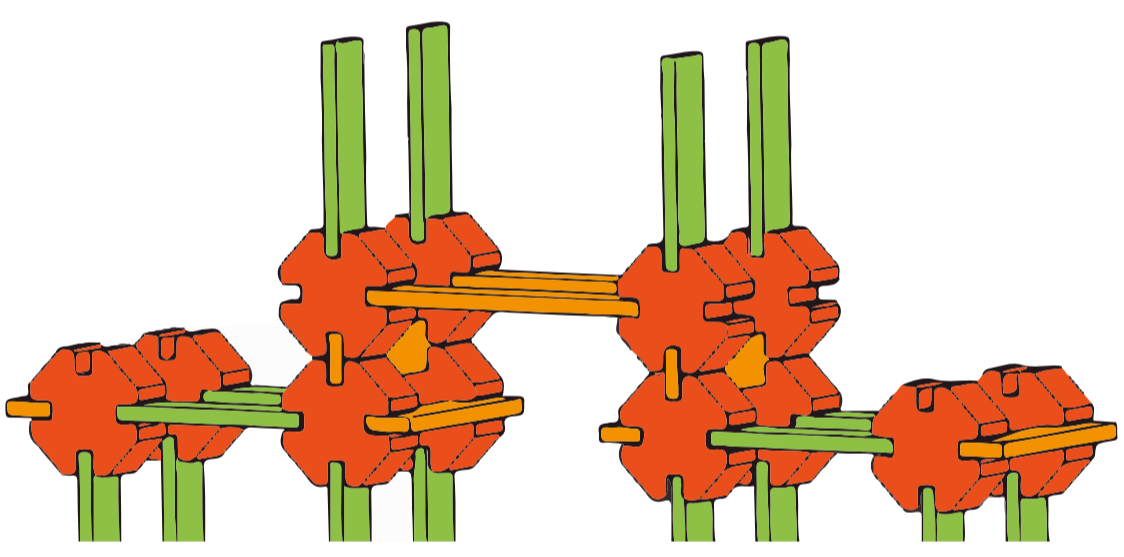

11  x4  x2

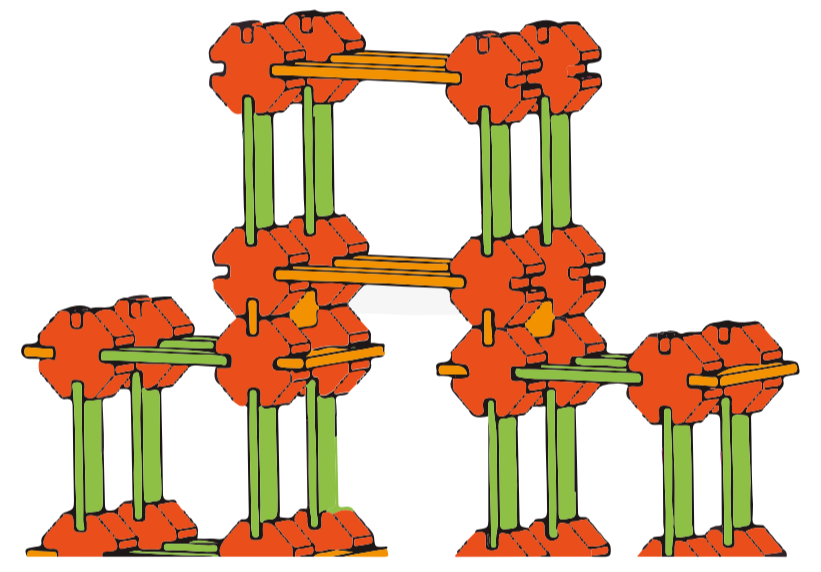

12  x4

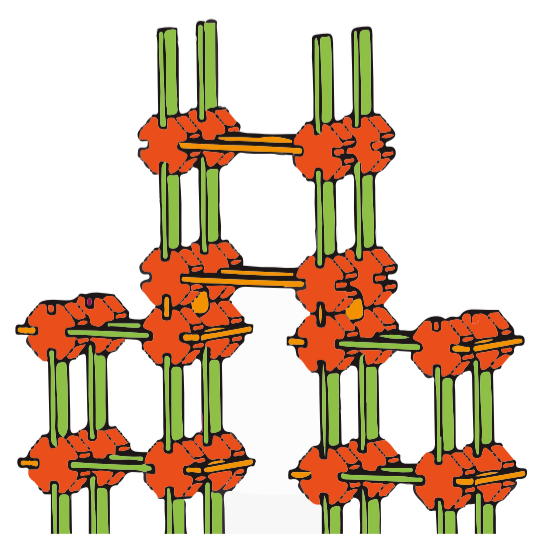

13  x4  x2

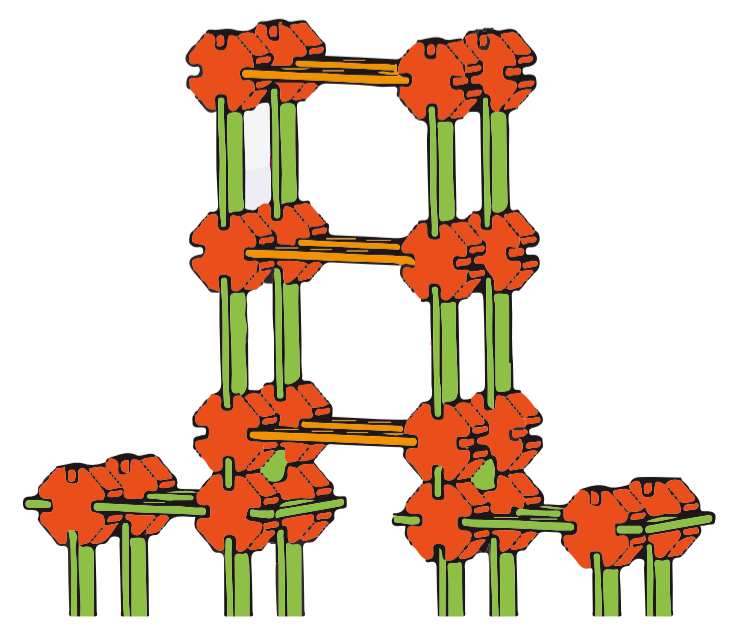

14  x2

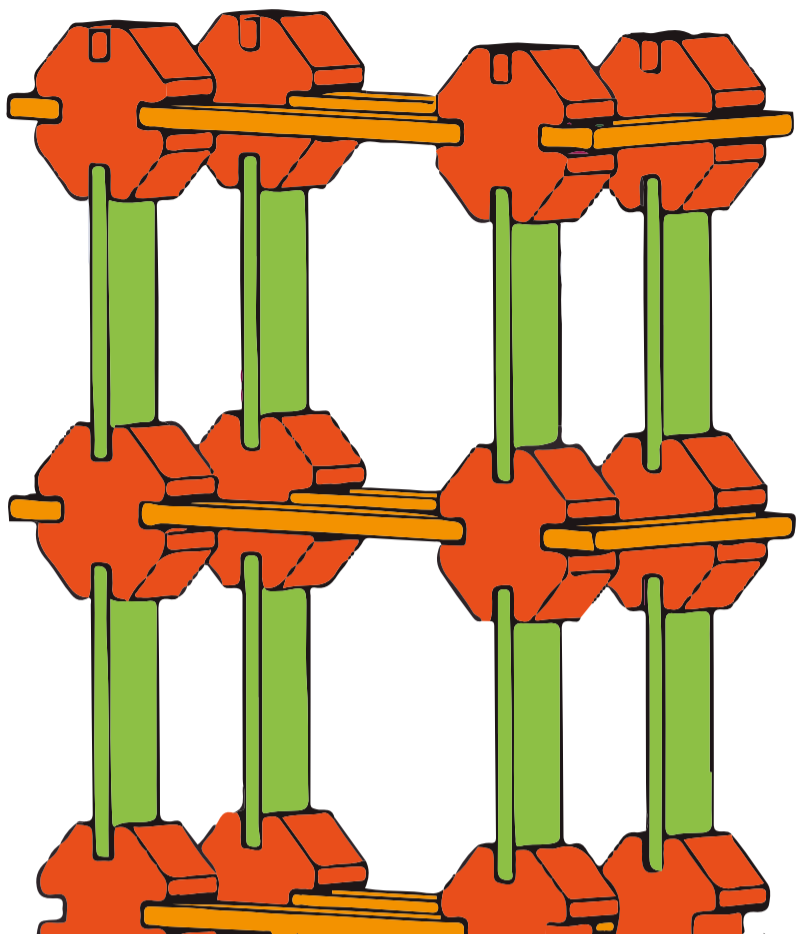

15  x4

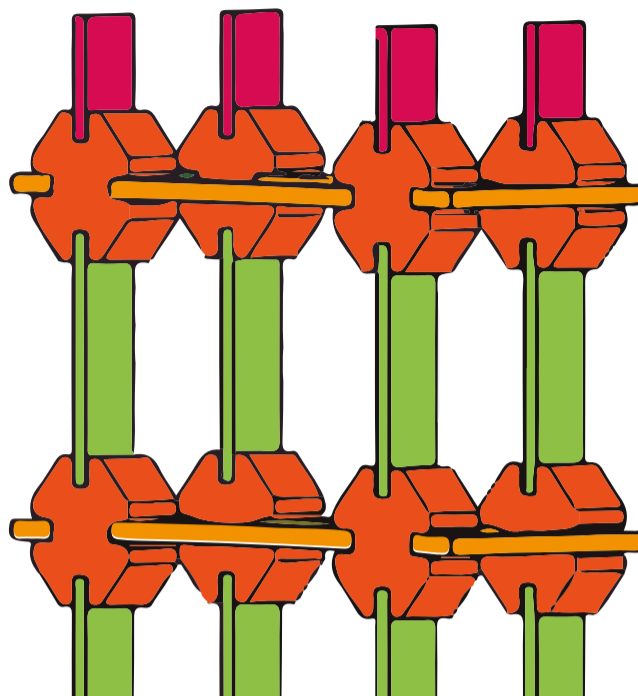

16  x4

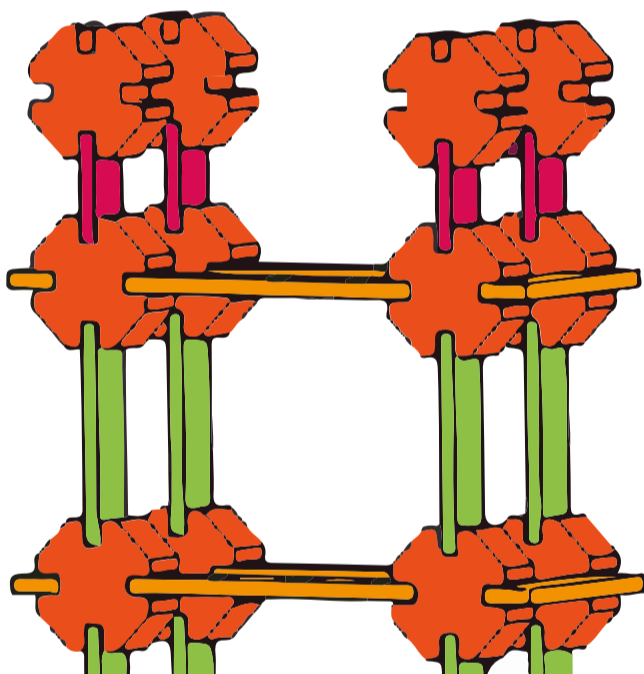

17  x2

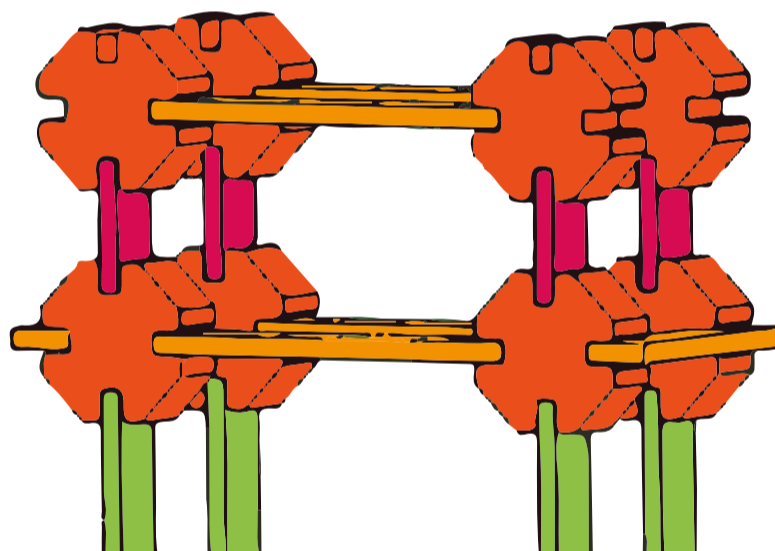

18  x36

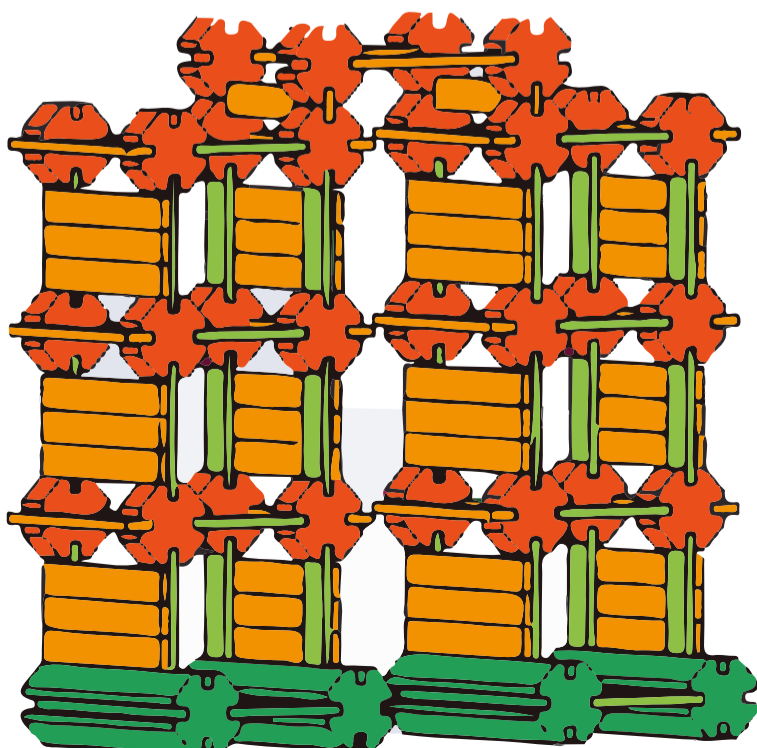

19  x14

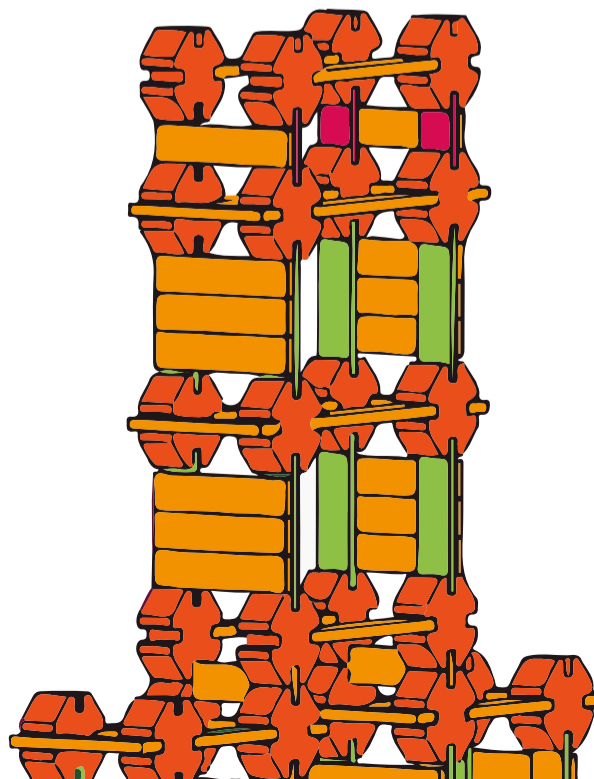

Construction du bras gauche

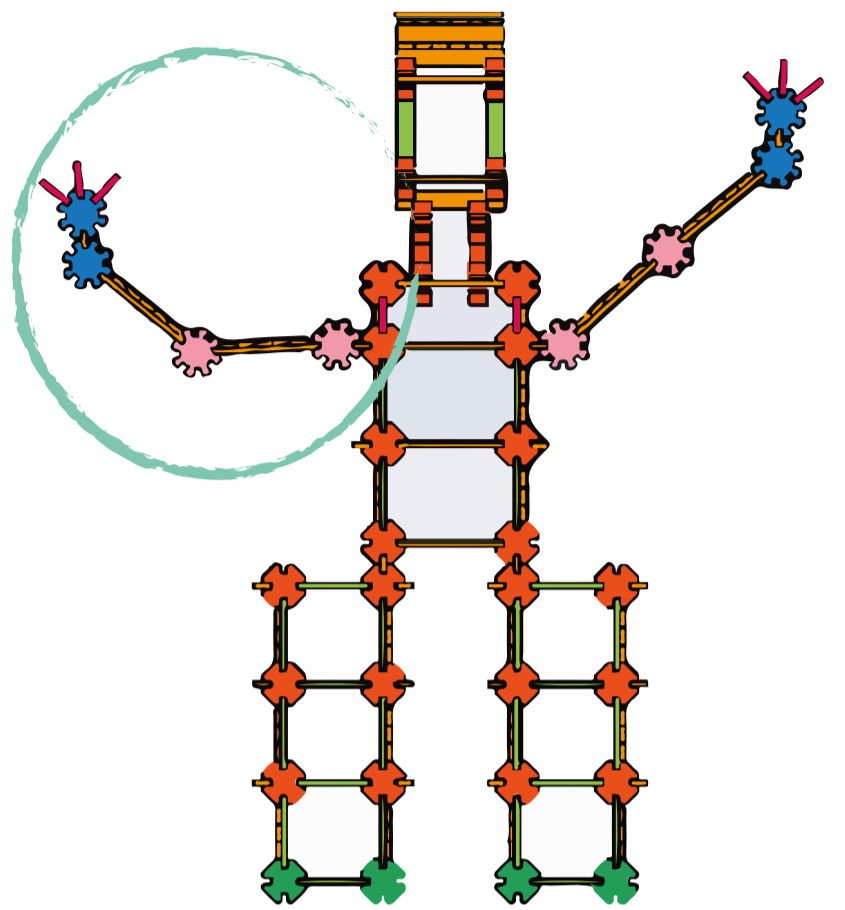

20  x2  x4

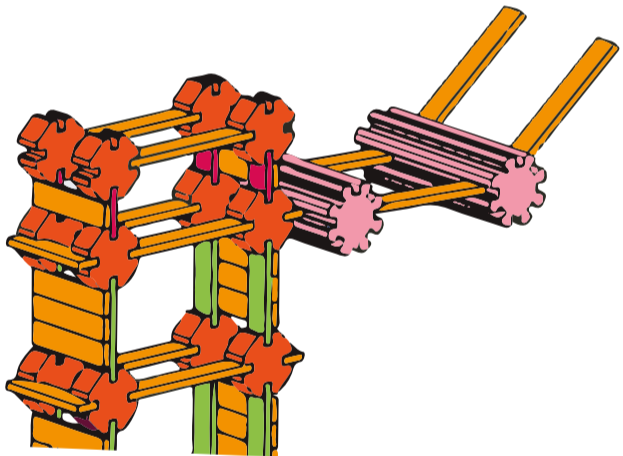

21  x10

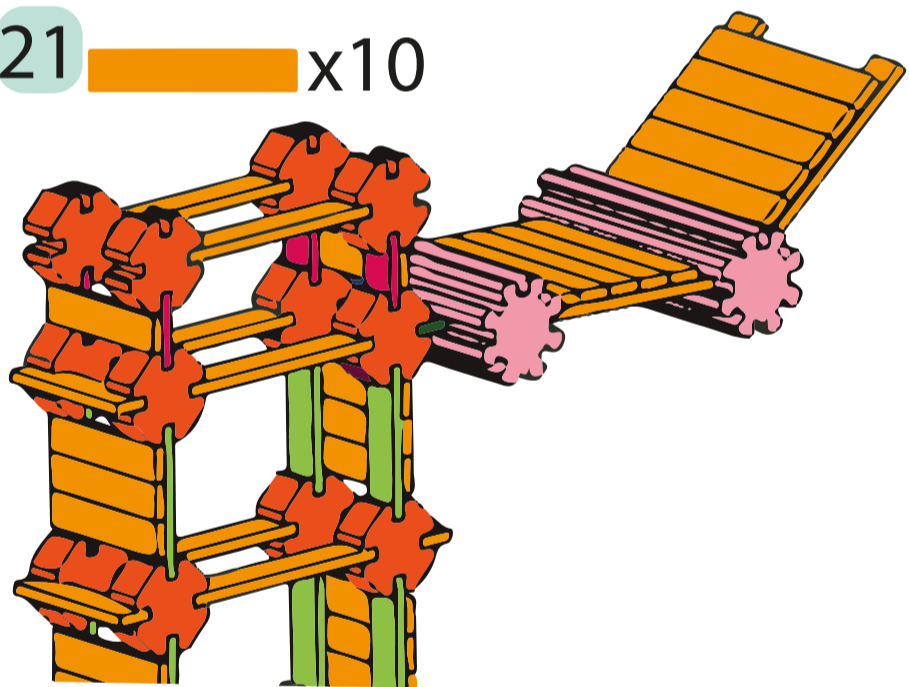

22  x2

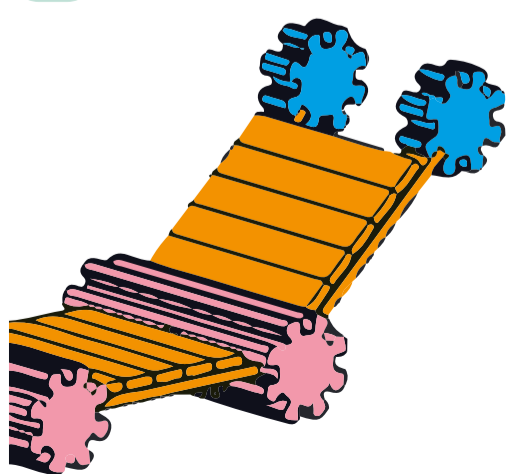

23  x1  x1  x3

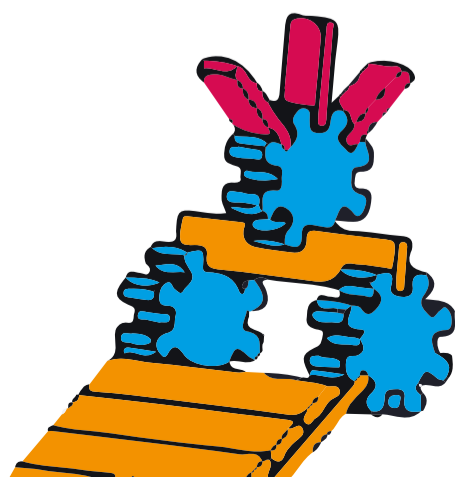

Construction du bras droit

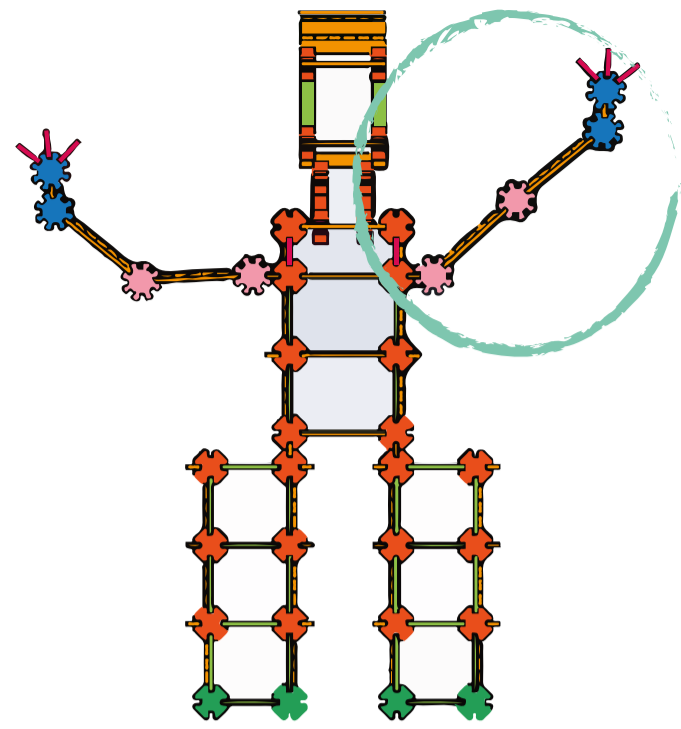

24  x2  x2

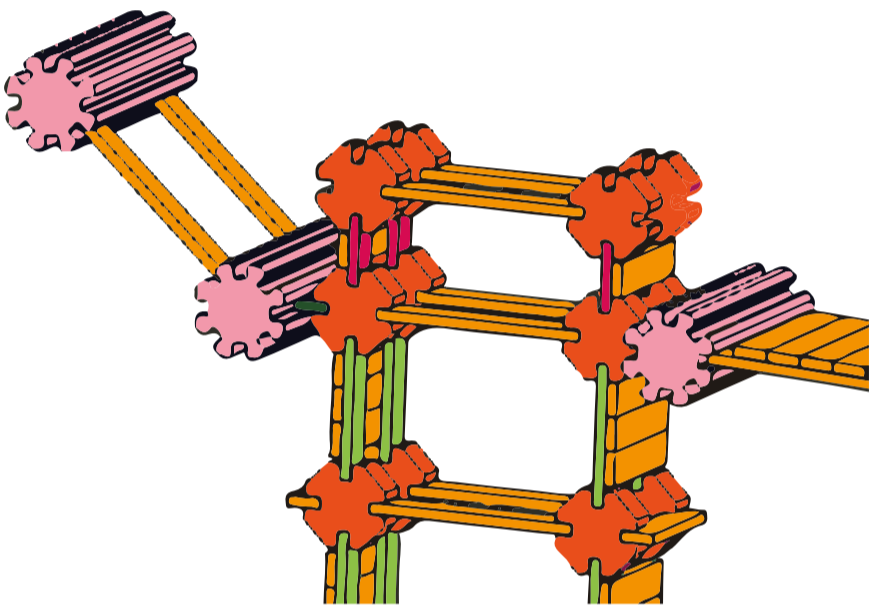

25  x5

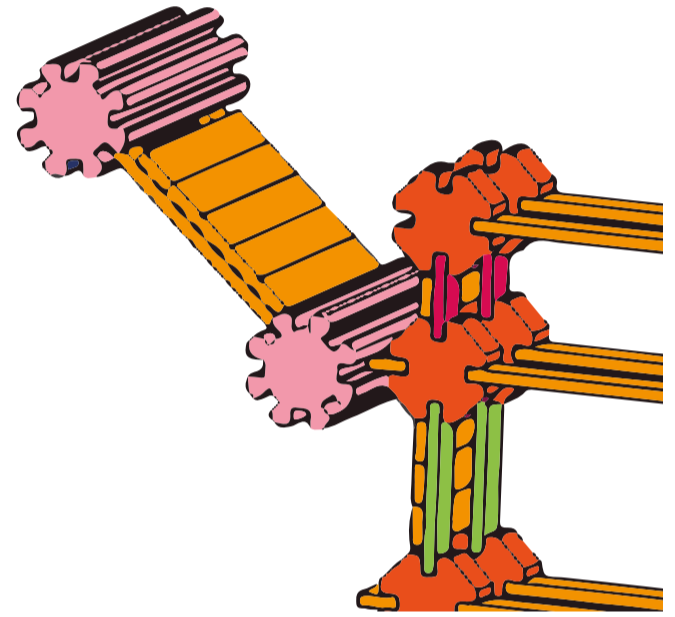

26  x2  x2

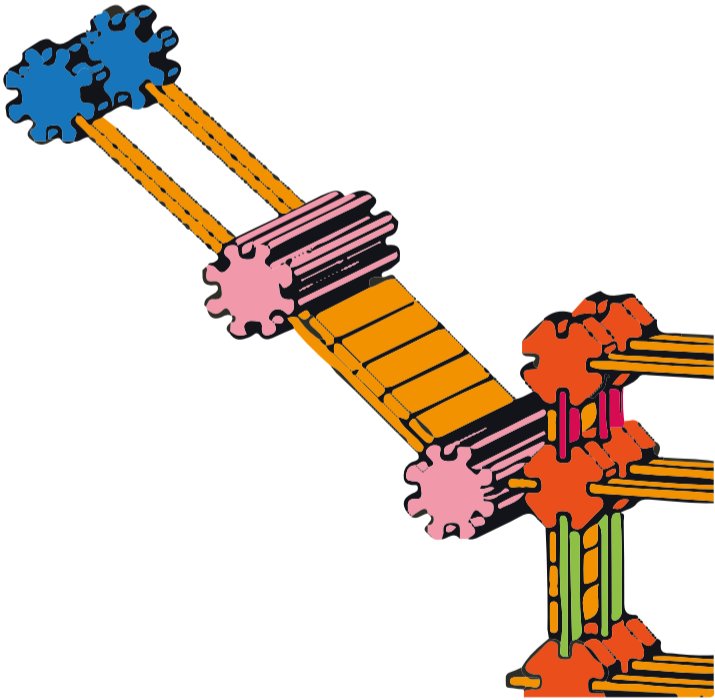

27  x6

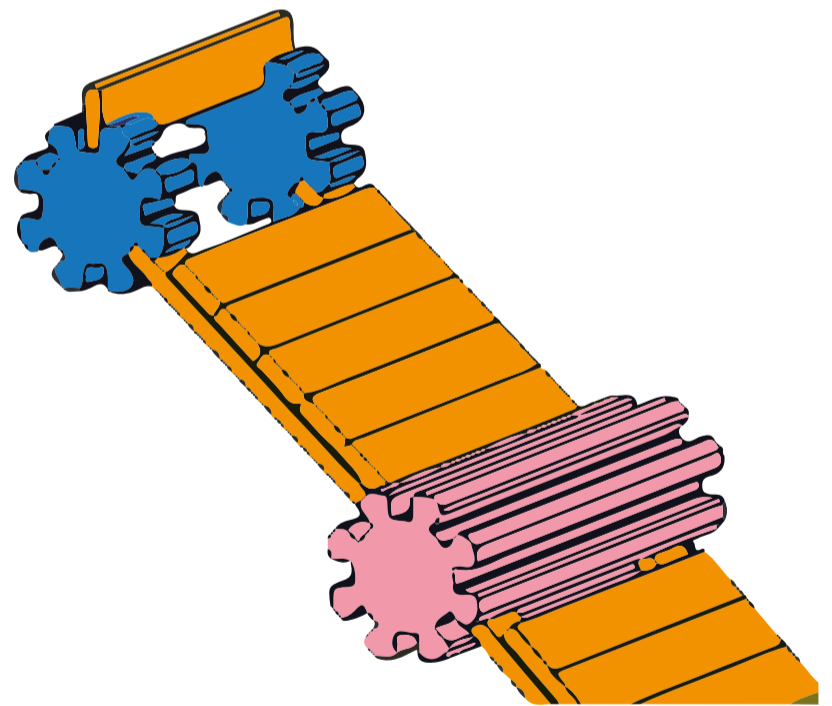

28  x1  x3

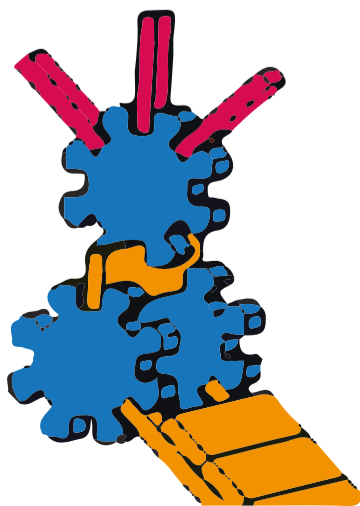

Construction de la tête

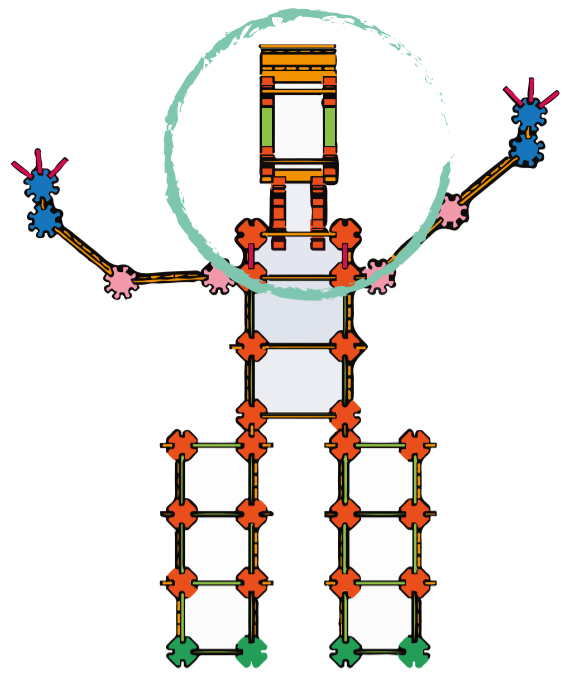

29  x4  x1  x2

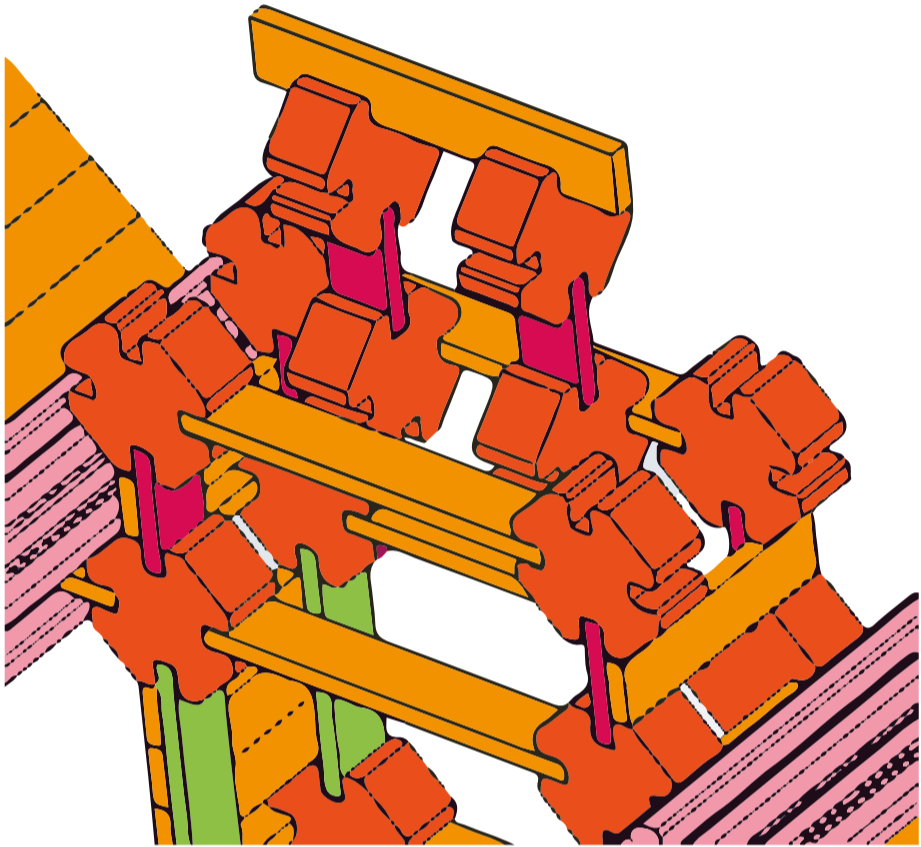

30  x4  x1  x2

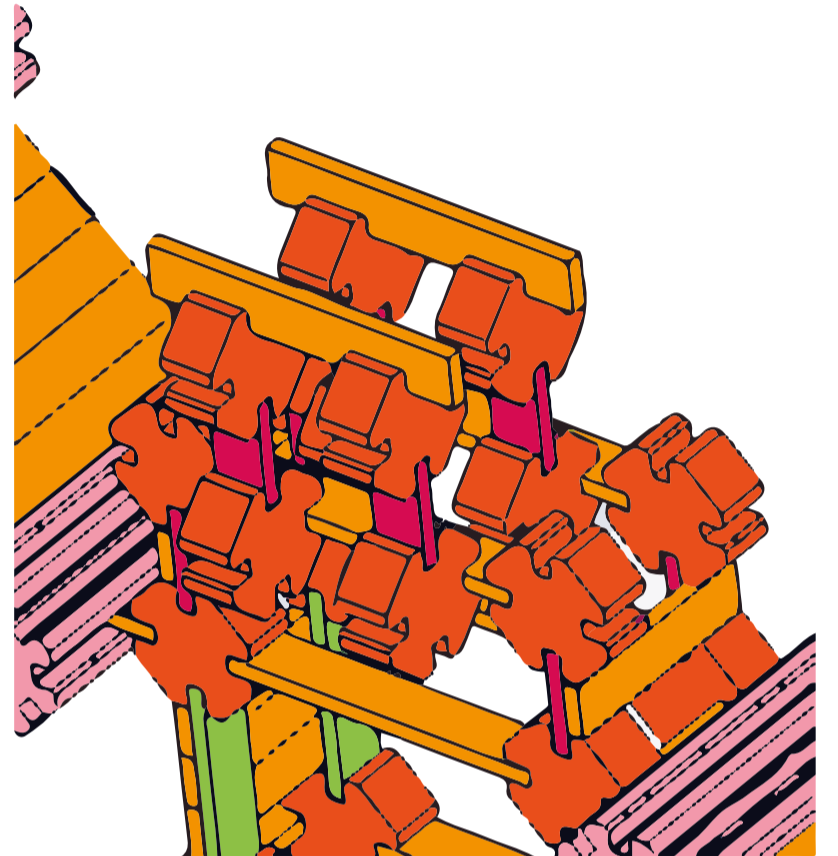

31  x4

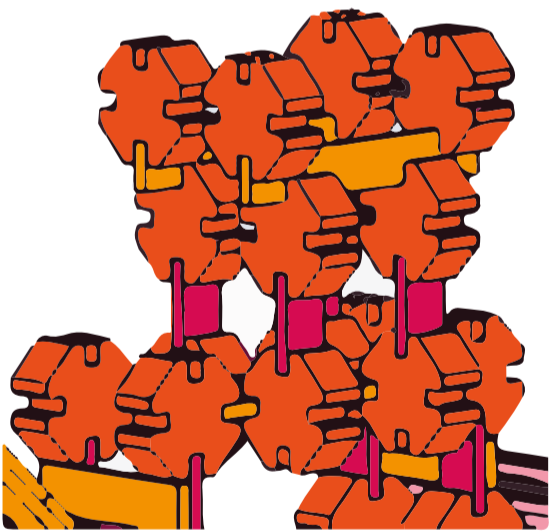

32  x2  x2

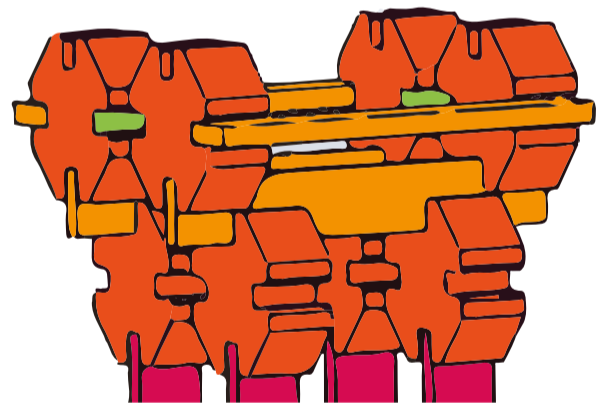

33  x4

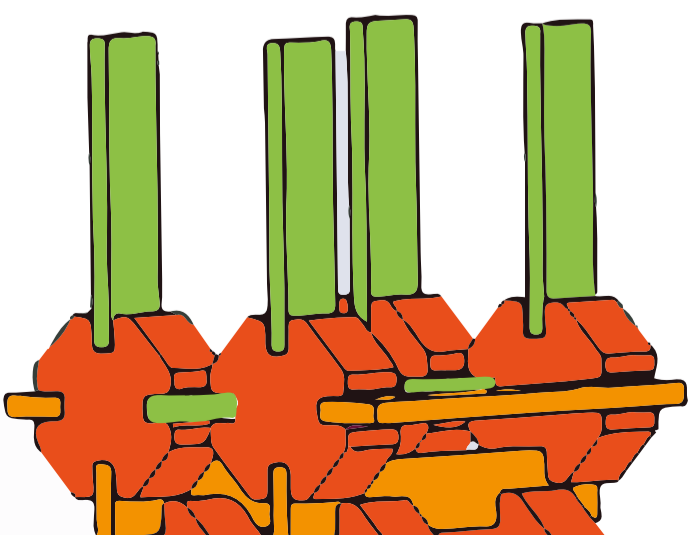

34  x4  x2  x2

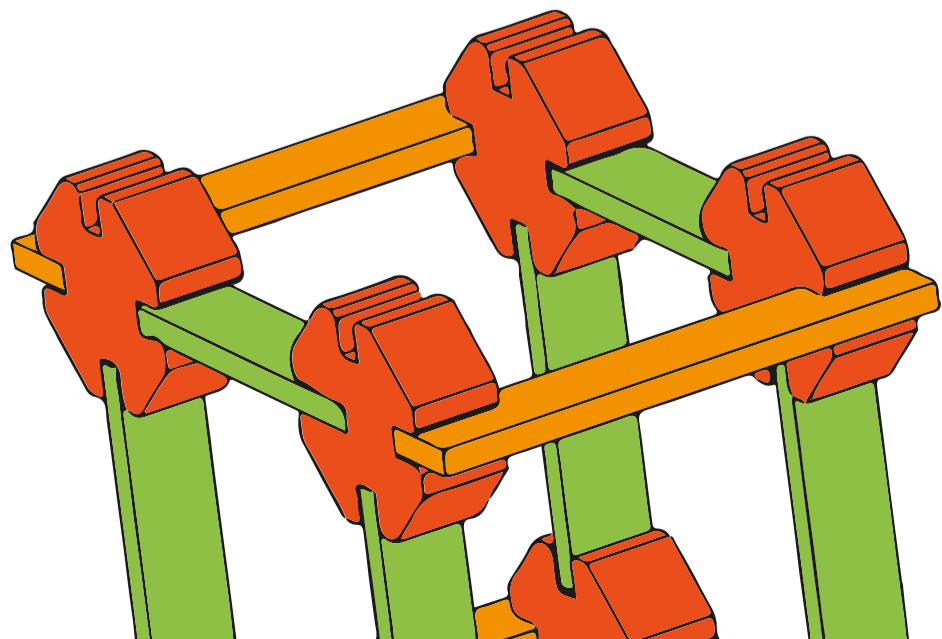

35  x2

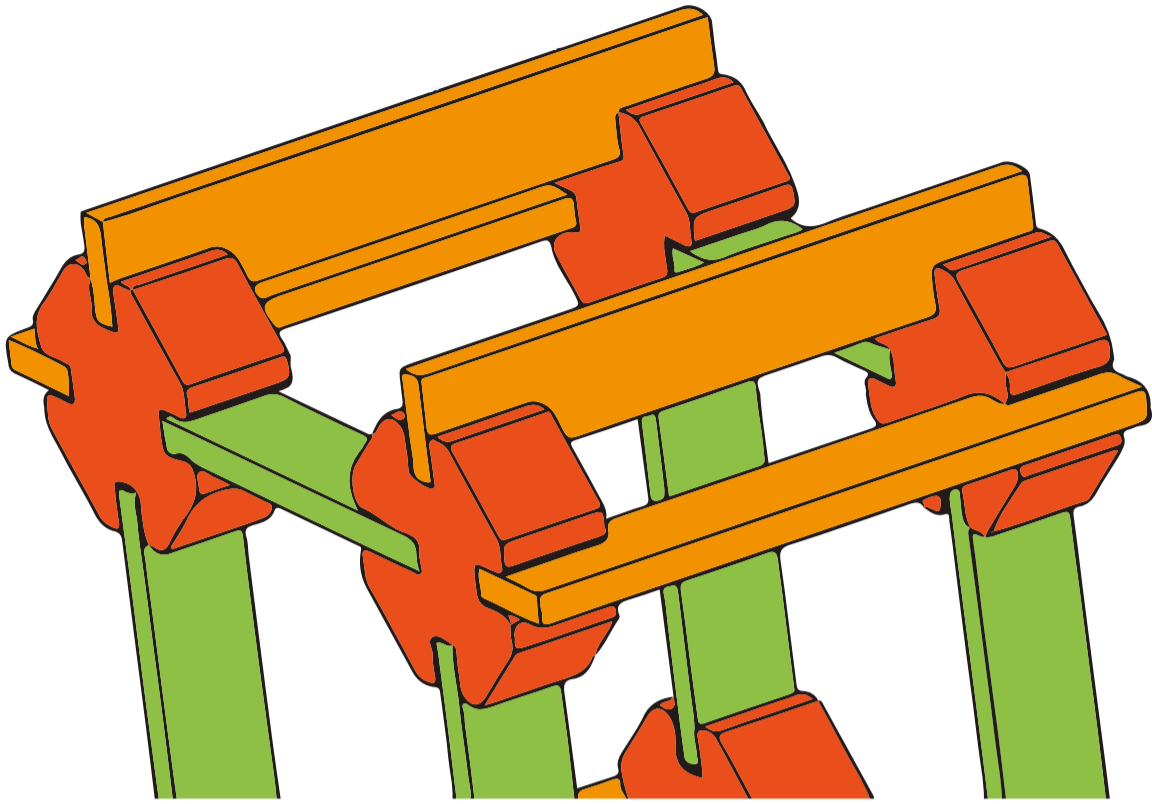

36  x6

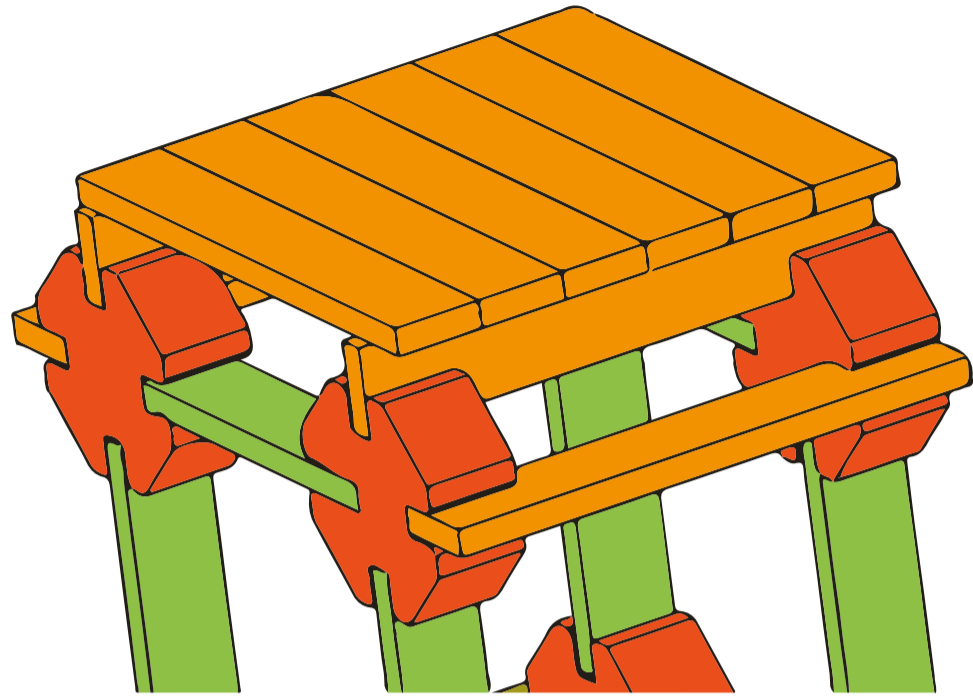

37  x3

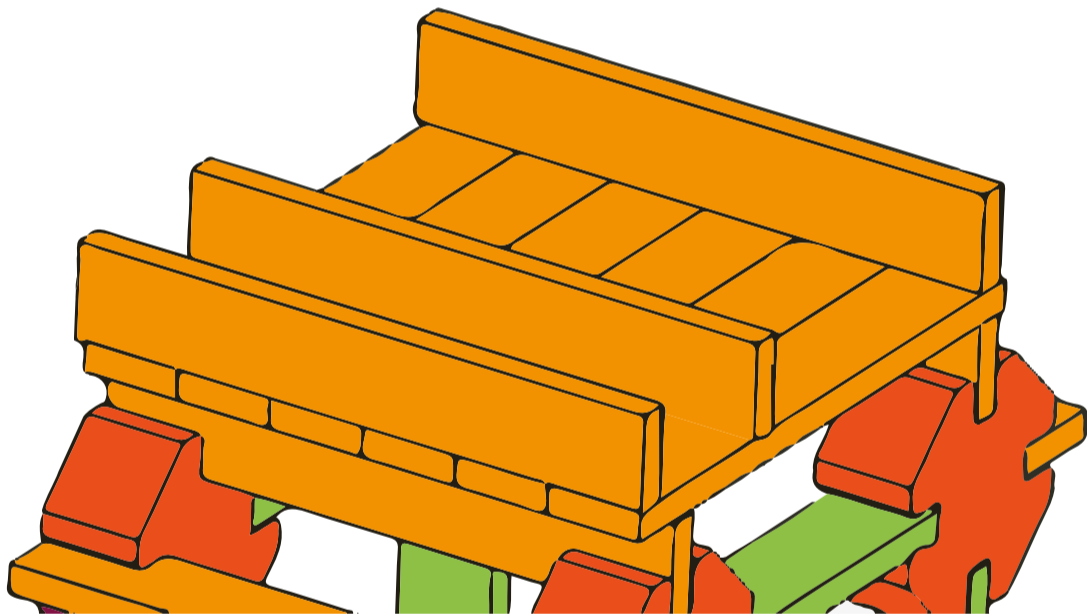

38  x6  x6

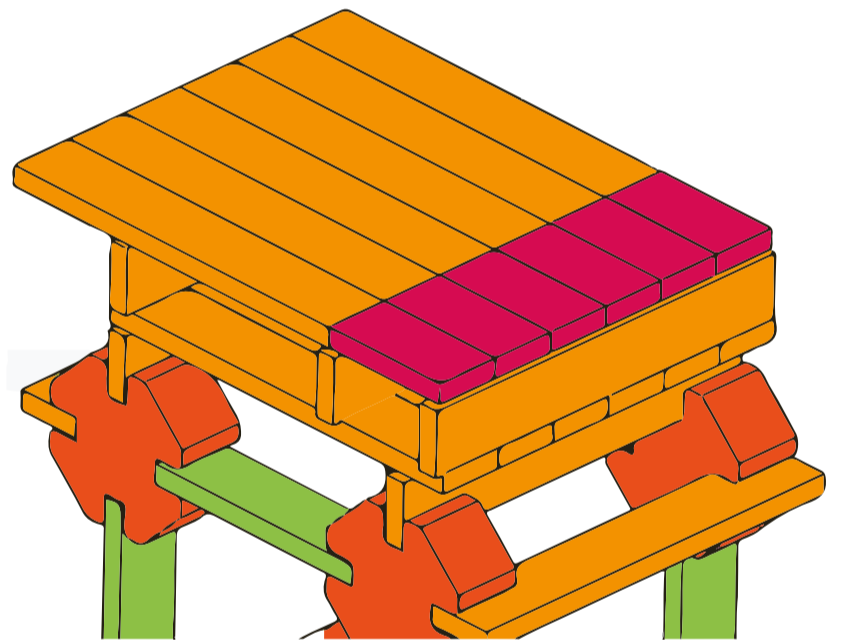

39  x2

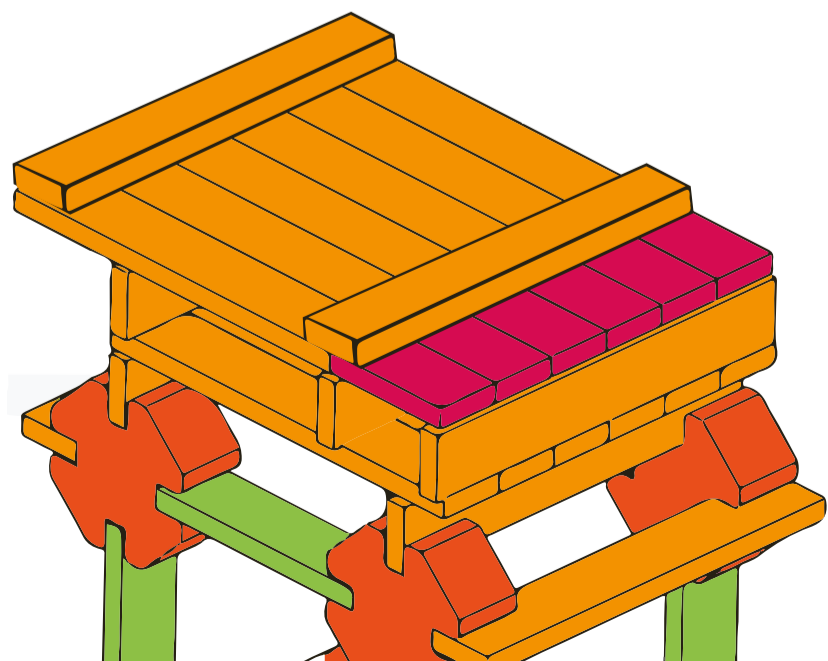

Décoration de Mr Truc en bois

Tu es joueur ???

Personnalise Mr Truc en bois, crée des motifs avec les pièces plates de différentes longueurs...

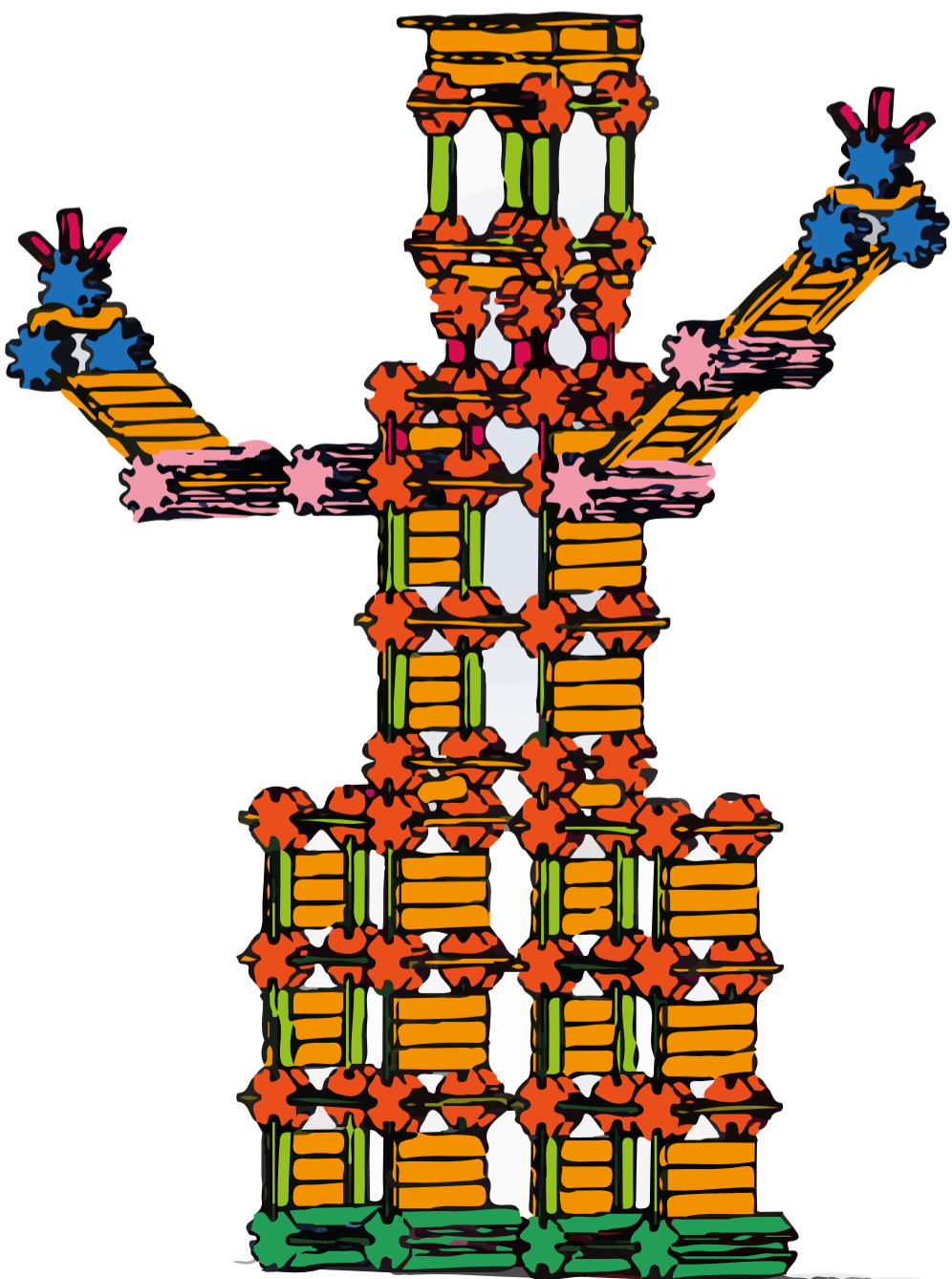
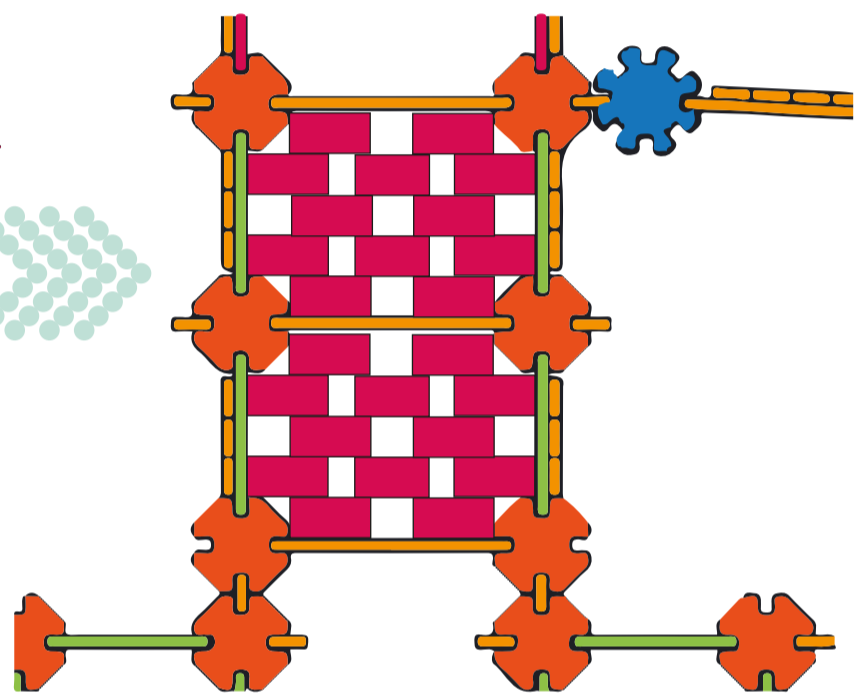
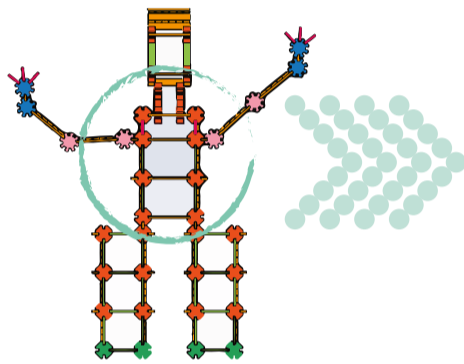
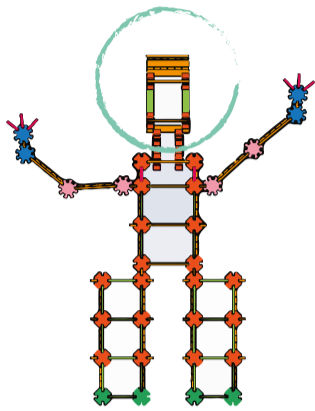
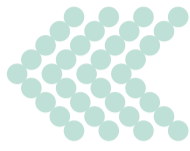
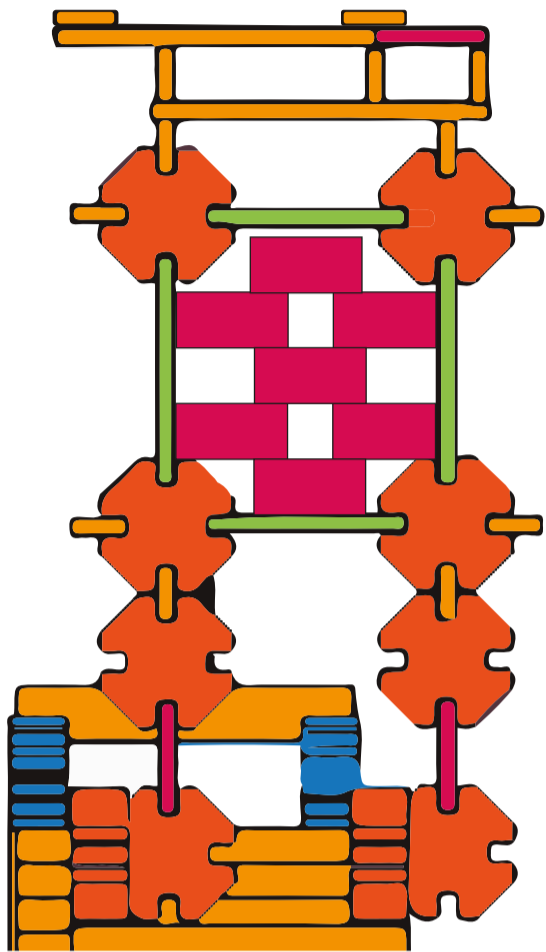

Mr

Truc en Bois